

CE-26 Brake Silencer Instructions



CE-26

Please read instructions before using.

© 2000 Goodtool

3/14/00

INSTRUCTIONS

1. Adjust the lathe to make your cut. Set the depth of the cut and tighten the knob on the top of the cutting head.
2. Adjust the spring on the silencer, if needed, to fit on the cutters with the notched edge against the cutting tips and with the spring behind the knob so that it will follow the cut.
3. Shut off the machine.
4. Place the silencer on the cutting head, notched side down against the tips, with the spring behind the knob on top of the cutting head. You will need to use two hands.
5. Turn on the machine and engage the clutch.
6. When the cut is finished, stop the machine and remove the silencer.

WARNING

For use with
Pro-Cut On-Car
Brake Lathe only.

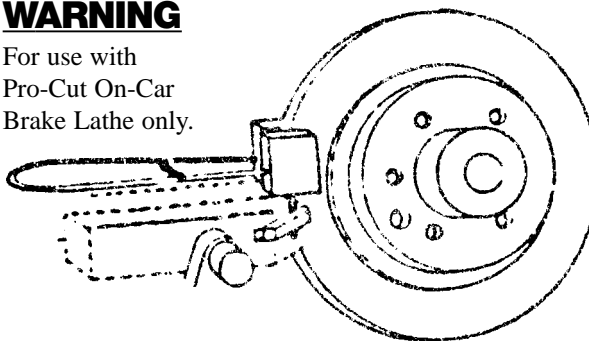

CE-26 Brake Silencer Instructions



CE-26

Please read instructions before using.

© 2000 Goodtool

3/14/00

INSTRUCTIONS

1. Adjust the lathe to make your cut. Set the depth of the cut and tighten the knob on the top of the cutting head.
2. Adjust the spring on the silencer, if needed, to fit on the cutters with the notched edge against the cutting tips and with the spring behind the knob so that it will follow the cut.
3. Shut off the machine.
4. Place the silencer on the cutting head, notched side down against the tips, with the spring behind the knob on top of the cutting head. You will need to use two hands.
5. Turn on the machine and engage the clutch.
6. When the cut is finished, stop the machine and remove the silencer.

WARNING

For use with
Pro-Cut On-Car
Brake Lathe only.

